

Post - Tensioned Concrete Design

For ACI 318-08

Post-Tensioning Concrete Design Codes

Chapter 1	Design for ACI 318-08	
1.1	Notations	1-1
1.2	Design Load Combinations	1-5
1.2.1	Initial Service Load Combination	1-5
1.2.2	Service Load Combination	1-5
1.2.3	Long-Term Service Load Combination	1-6
1.2.4	Strength Design Load Combination	1-6
1.3	Limit on Material Strength	1-7
1.4	Strength Reduction Factors	1-7
1.5	Design Assumptions for Prestressed Concrete	1-8
1.6	Serviceability Requirements of Flexural Members	1-10
1.6.1	Serviceability Check at Initial Service Load	1-10
1.6.2	Serviceability Checks at Service Load	1-10
1.6.3	Serviceability Checks at Long-Term Service Load	1-11
1.6.4	Serviceability Checks of Prestressing Steel	1-11
1.7	Beam Design	1-12
1.7.1	Design Flexural Reinforcement	1-12
1.7.2	Design Beam Shear Reinforcement	1-23
1.7.3	Design Beam Torsion Reinforcement	1-26
1.8	Slab Design	1-31
1.8.1	Design for Flexure	1-31
1.8.2	Check for Punching Shear	1-33
1.8.3	Design Punching Shear Reinforcement	1-37

Post-Tensioned Concrete Design for ACI 318-08

Herein describes in detail the various aspects of the post-tensioned concrete design procedure with the American code ACI 318-08 [ACI 2008]. Various notations used in this chapter are listed in Table 1-1. For referencing to the pertinent sections of the ACI code in this chapter, a prefix “ACI” followed by the section number is used.

1.1 Notations

The following table identifies the various notations used in this chapter.

Table 1-1 List of Symbols Used in the ACI 318-08 Code

A_{cp}	Area enclosed by the outside perimeter of the section, in ²
A_g	Gross area of concrete, in ²
A_l	Total area of longitudinal reinforcement to resist torsion, in ²
A_o	Area enclosed by the shear flow path, sq-in
A_{oh}	Area enclosed by the centerline of the outermost closed transverse torsional reinforcement, sq-in
A_{ps}	Area of prestressing steel in flexural tension zone, in ²
A_s	Area of tension reinforcement, in ²
A'_s	Area of compression reinforcement, in ²
$A_{s(required)}$	Area of steel required for tension reinforcement, in ²
A_t/s	Area of closed shear reinforcement per unit length of member for torsion, sq-in/in
A_v	Area of shear reinforcement, in ²
A_v/s	Area of shear reinforcement per unit length of member, in ² /in
a	Depth of compression block, in
a_b	Depth of compression block at balanced condition, in
a_{max}	Maximum allowed depth of compression block, in
b	Width of member, in
b_f	Effective width of flange (T-beam section), in
b_w	Width of web (T-beam section), in
b_o	Perimeter of the punching critical section, in
b_1	Width of the punching critical section in the direction of bending, in
b_2	Width of the punching critical section perpendicular to the direction of bending, in
c	Depth to neutral axis, in
c_b	Depth to neutral axis at balanced conditions, in

Table 1-1 List of Symbols Used in the ACI 318-08 Code

d	Distance from compression face to tension reinforcement, in
d'	Concrete cover to center of reinforcing, in
d_e	Effective depth from compression face to centroid of tension reinforcement, in
d_s	Thickness of slab (T-beam section), in
d_p	Distance from extreme compression fiber to centroid of prestressing steel, in
E_c	Modulus of elasticity of concrete, psi
E_s	Modulus of elasticity of reinforcement, assumed as 29,000,000 psi (ACI 8.5.2)
f'_c	Specified compressive strength of concrete, psi
f'_{ci}	Specified compressive strength of concrete at time of initial prestress, psi
f_{pe}	Compressive stress in concrete due to effective prestress forces only (after allowance of all prestress losses), psi
f_{ps}	Stress in prestressing steel at nominal flexural strength, psi
f_{pu}	Specified tensile strength of prestressing steel, psi
f_{py}	Specified yield strength of prestressing steel, psi
f_t	Extreme fiber stress in tension in the precompressed tensile zone using gross section properties, psi
f_y	Specified yield strength of flexural reinforcement, psi
f_{ys}	Specified yield strength of shear reinforcement, psi
h	Overall depth of a section, in
h_f	Height of the flange, in
ϕM_n^o	Design moment resistance of a section with tendons only, N-mm

Table 1-1 List of Symbols Used in the ACI 318-08 Code

ϕM_n^{bal}	Design moment resistance of a section with tendons and the necessary mild reinforcement to reach the balanced condition, N-mm
M_u	Factored moment at section, lb-in
N_c	Tension force in concrete due to unfactored dead load plus live load, lb
P_u	Factored axial load at section, lb
s	Spacing of the shear reinforcement along the length of the beam, in
T_u	Factored torsional moment at section, lb-in
V_c	Shear force resisted by concrete, lb
V_{max}	Maximum permitted total factored shear force at a section, lb
V_u	Factored shear force at a section, lb
V_s	Shear force resisted by steel, lb
β_1	Factor for obtaining depth of compression block in concrete
β_c	Ratio of the maximum to the minimum dimensions of the punching critical section
ϵ_c	Strain in concrete
$\epsilon_{c, max}$	Maximum usable compression strain allowed in extreme concrete fiber (0.003 in/in)
ϵ_{ps}	Strain in prestressing steel
$\epsilon_{s, min}$	Strain in reinforcing steel
ϵ	Minimum tensile strain allowed in steel reinforcement at nominal strength for tension controlled behavior (0.005 in/in)
ϕ	Strength reduction factor
γ_f	Fraction of unbalanced moment transferred by flexure
γ_v	Fraction of unbalanced moment transferred by eccentricity of shear

Table 1-1 List of Symbols Used in the ACI 318-08 Code

λ	Shear strength reduction factor for light-weight concrete
θ	Angle of compression diagonals, degrees

1.2 Design Load Combinations

The design load combinations are the various combinations of the load cases for which the structure needs to be designed. For ACI 318-08, if a structure is subjected to dead (D), live (L), pattern live (PL), snow (S), wind (W), and earthquake (E) loads, and considering that wind and earthquake forces are reversible, the load combinations in the following sections may need to be considered (ACI 9.2.1).

For post-tensioned concrete design, the user can specify the prestressing load (PT) by providing the tendon profile. The default load combinations for post-tensioning are defined in the following sections.

1.2.1 Initial Service Load Combination

The following load combination is used for checking the requirements at transfer of prestress forces, in accordance with ACI 318-08 clause 18.4.1. The prestressing forces are considered without any long-term losses for the initial service load combination check.

$$1.0D + 1.0PT \quad (\text{ACI 18.4.1})$$

1.2.2 Service Load Combination

The following load combinations are used for checking the requirements of prestress for serviceability in accordance with ACI 318-08 clauses 18.3.3, 18.4.2(b), and 18.9.3.2. It is assumed that all long-term losses have already occurred at the service stage.

$$1.0D + 1.0PT$$
$$1.0D + 1.0L + 1.0PT \quad (\text{ACI 18.4.2(b)})$$

1.2.3 Long-Term Service Load Combination

The following load combinations are used for checking the requirements of prestress in accordance with ACI 318-08 clause 18.4.2(a). The permanent load for this load combination is taken as 50 percent of the live load. It is assumed that all long-term losses have already occurred at the service stage.

$$\begin{aligned} 1.0D + 1.0PT \\ 1.0D + 0.5L + 1.0PT \end{aligned} \quad (\text{ACI 18.4.2(b)})$$

1.2.4 Strength Design Load Combination

The following load combinations are used for checking the requirements of prestress for strength in accordance with ACI 318-08, Chapters 9 and 18.

The strength design combinations required for shear design of beams and punching shear require the full PT forces (primary and secondary). Flexural design requires only the hyperstatic (secondary) forces. The hyperstatic (secondary) forces are automatically determined by subtracting out the primary PT moments when the flexural design is carried out.

$$\begin{aligned} 1.4D + 1.0PT^* & \quad (\text{ACI 9.2.1}) \\ 1.2D + 1.6L + 1.0PT^* & \quad (\text{ACI 9.2.1}) \\ 1.2D + 1.6(0.75 PL) + 1.0PT^* & \quad (\text{ACI 9.2.1, 13.7.6.3}) \\ 0.9D \pm 1.6W + 1.0PT^* & \quad (\text{ACI 9.2.1}) \\ 1.2D + 1.0L \pm 1.6W + 1.0PT^* & \\ 0.9D \pm 1.0E + 1.0PT^* & \quad (\text{ACI 9.2.1}) \\ 1.2D + 1.0L \pm 1.0E + 1.0PT^* & \\ 1.2D + 1.6L + 0.5S + 1.0PT^* & \quad (\text{ACI 9.2.1}) \\ 1.2D + 1.0L + 1.6S + 1.0PT^* & \\ 1.2D + 1.6S \pm 0.8W + 1.0PT^* & \quad (\text{ACI 9.2.1}) \\ 1.2D + 1.0L + 0.5S \pm 1.6W + 1.0PT^* & \\ 1.2D + 1.0L + 0.2S \pm 1.0E + 1.0PT^* & \quad (\text{ACI 9.2.1}) \end{aligned}$$

* — Replace PT by H for flexural design only

The IBC 2006 basic load combinations (Section 1605.2.1) are the same. These also are the default design load combinations whenever the ACI 318-08 code is used. The user should use other appropriate load combinations if roof live load is treated separately, or if other types of loads are present.

1.3 Limits on Material Strength

The concrete compressive strength, f'_c , should not be less than 2500 psi (ACI 5.1.1). The upper limit of the reinforcement yield strength, f_y , is taken as 80 ksi (ACI 9.4) and the upper limit of the reinforcement shear strength, f_v , is taken as 60 ksi (ACI 11.5.2).

This procedure enforces the upper material strength limits for flexure and shear design of beams and slabs or for torsion design of beams. The input material strengths are taken as the upper limits if they are defined in the material properties as being greater than the limits. The user is responsible for ensuring that the minimum strength is satisfied.

1.4 Strength Reduction Factors

The strength reduction factors, ϕ , are applied on the specified strength to obtain the design strength provided by a member. The ϕ factors for flexure, shear, and torsion are as follows:

$$\phi_t = 0.90 \text{ for flexure (tension controlled)} \quad (\text{ACI 9.3.2.1})$$

$$\phi_c = 0.65 \text{ for flexure (compression controlled)} \quad (\text{ACI 9.3.2.2(b)})$$

$$\phi = 0.75 \text{ for shear and torsion.} \quad (\text{ACI 9.3.2.3})$$

The value of ϕ varies from compression-controlled to tension-controlled based on the maximum tensile strain in the reinforcement at the extreme edge, ϵ_t , (ACI 9.3.2.2).

Sections are considered compression-controlled when the tensile strain in the extreme tension reinforcement is equal to or less than the compression-controlled strain limit at the time the concrete in compression reaches its assumed strain limit of $\epsilon_{c,\max}$, which is 0.003. The compression-controlled strain

limit is the tensile strain in the reinforcement at the balanced strain condition, which is taken as the yield strain of the reinforcement, (f_y/E) (ACI 10.3.3).

Sections are tension-controlled when the tensile strain in the extreme tension reinforcement is equal to or greater than 0.005, just as the concrete in compression reaches its assumed strain limit of 0.003 (ACI 10.3.4).

Sections with ϵ_t between the two limits are considered to be in a transition region between compression-controlled and tension-controlled sections (ACI 10.3.4).

When the section is tension-controlled, ϕ_t is used. When the section is compression-controlled, ϕ_c is used. When the section is in the transition region, ϕ is linearly interpolated between the two values (ACI 9.3.2).

1.5 Design Assumptions for Prestressed Concrete

Strength design of prestressed members for flexure and axial loads shall be based on assumptions given in ACI 10.2.

- The strain in the reinforcement and concrete shall be assumed directly proportional to the distance from the neutral axis (ACI 10.2.2).
- The maximum usable strain at the extreme concrete compression fiber shall be assumed equal to 0.003 (ACI 10.2.3).
- The tensile strength of the concrete shall be neglected in axial and flexural calculations (ACI 10.2.5).
- The relationship between the concrete compressive stress distribution and the concrete strain shall be assumed to be rectangular by an equivalent rectangular concrete stress distribution (ACI 10.2.7).
- The concrete stress of $0.85f'_c$ shall be assumed uniformly distributed over an equivalent-compression zone bounded by edges of the cross-section and a straight line located parallel to the neutral axis at a distance $a = \beta_1 c$ from the fiber of maximum compressive strain (ACI 10.2.7.1).

- The distance from the fiber of maximum strain to the neutral axis, c shall be measured in a direction perpendicular to the neutral axis (ACI 10.2.7.2).

Elastic theory shall be used with the following two assumptions:

- The strains shall vary linearly with depth through the entire load range (ACI 18.3.2.1).
- At cracked sections, the concrete resists no tension (ACI 18.3.2.1). Prestressed

concrete members are investigated at the following three stages (ACI 18.3.2):

- At transfer of prestress force
- At service loading
- At nominal strength

The prestressed flexural members are classified as Class U (uncracked), Class T (transition), and Class C (cracked) based on f_t , the computed extreme fiber stress in tension in the precompressed tensile zone at service loads (ACI 18.3.3).

The precompressed tensile zone is that portion of a prestressed member where flexural tension, calculated using gross section properties, would occur under unfactored dead and live loads if the prestress force was not present. Prestressed concrete is usually designed so that the prestress force introduces compression into this zone, thus effectively reducing the magnitude of the tensile stress.

For Class U and Class T flexural members, stresses at service load are determined using uncracked section properties, while for Class C flexural members, stresses at service load are calculated based on the cracked section (ACI 18.3.4).

A prestressed two-way slab system is designed as Class U only with $f_t \leq 6\sqrt{f'_c}$ (ACI R18.3.3); otherwise, an over-stressed (O/S) condition is reported.

Post-Tensioned Concrete Design

The following table provides a summary of the conditions considered for the various section classes.

Assumed behavior	Prestressed			Nonprestressed
	Class U	Class T	Class C	
	Uncracked	Transition between uncracked and cracked	Cracked	Cracked
Section properties for stress calculation at service loads	Gross section 18.3.4	Gross section 18.3.4	Cracked section 18.3.4	No requirement
Allowable stress at transfer	18.4.1	18.4.1	18.4.1	No requirement
Allowable compressive stress based on uncracked section properties	18.4.2	18.4.2	No requirement	No requirement
Tensile stress at service loads 18.3.3	$\leq 7.5 \sqrt{f'_c}$	$7.5 \sqrt{f'_c} < f_t \leq 12 \sqrt{f'_c}$	No requirement	No requirement

1.6 Serviceability Requirements of Flexural Members

1.6.1 Serviceability Check at Initial Service Load

The stresses in the concrete immediately after prestress force transfer (before time dependent prestress losses) are checked against the following limits:

- Extreme fiber stress in compression: $0.60 f'_{ci}$ (ACI 18.4.1(a))
- Extreme fiber stress in tension: $3\sqrt{f'_{ci}}$ (ACI 18.4.1(b))
- Extreme fiber stress in tension at ends of simply supported members: $6\sqrt{f'_{ci}}$ (ACI 18.4.1(c))

1.6.2 Serviceability Checks at Service Load

The stresses in the concrete for Class U and Class T prestressed flexural members at service loads, and after all prestress losses occur, are checked against the following limits:

- Extreme fiber stress in compression due to prestress plus total load: $0.60f'_c$ (ACI 18.4.2(b))
- Extreme fiber stress in tension in the precompressed tensile zone at service loads:
 - Class U beams and one-way slabs: $f_t \leq 7.5\sqrt{f'_c}$ (ACI 18.3.3)
 - Class U two-way slabs: $f_t \leq 6\sqrt{f'_c}$ (ACI 18.3.3)
 - Class T beams: $7.5\sqrt{f'_c} < f_t \leq 12\sqrt{f'_c}$ (ACI 18.3.3)
 - Class C beams: $f_t \geq 12\sqrt{f'_c}$ (ACI 18.3.3)

For Class C prestressed flexural members, checks at service loads are not required by the code. However, for Class C prestressed flexural members not subject to fatigue or to aggressive exposure, the spacing of bonded reinforcement nearest the extreme tension face shall not exceed that given by ACI 10.6.4 (ACI 18.4.4). It is assumed that the user has checked the requirements of ACI 10.6.4 and ACI 18.4.4.1 to 18.4.4 independently.

1.6.3 Serviceability Checks at Long-Term Service Load

The stresses in the concrete for Class U and Class T prestressed flexural members at long-term service loads, and after all prestress losses occur, are checked against the same limits as for the normal service load, except for the following:

- Extreme fiber stress in compression due to prestress plus total load:

$$0.45f'_c \quad (\text{ACI 18.4.2(a)})$$

1.6.4 Serviceability Checks of Prestressing Steel

Perform checks on the tensile stresses in the prestressing steel (ACI 18.5.1). The permissible tensile stress checks, in all types of

Post-Tensioned Concrete Design

prestressing steel, in terms of the specified minimum tensile stress f_{pu} , and the minimum yield stress, f_y , are summarized as follows:

- Due to tendon jacking force: $\min(0.94f_{py}, 0.80f_{pu})$ (ACI 18.5.1(a))
- Immediately after force transfer: $\min(0.82f_{py}, 0.74f_{pu})$ (ACI 18.5.1(b))
- At anchors and couplers after force transfer: $0.70f_{pu}$ (ACI 18.5.1(c))

1.7 Beam Design

In the design of prestressed concrete beams, calculates and reports the required areas of reinforcement for flexure, shear, and torsion based on the beam moments, shear forces, torsion, load combination factors, and other criteria described in the subsections that follow. The reinforcement requirements are calculated at each station along the length of the beam.

Beams are designed for major direction flexure, shear, and torsion only. Effects resulting from any axial forces and minor direction bending that may exist in the beams must be investigated independently by the user.

The beam design procedure involves the following steps:

- Design flexural reinforcement
- Design shear reinforcement
- Design torsion reinforcement

1.7.1 Design Flexural Reinforcement

The beam top and bottom flexural reinforcement is designed at each station along the beam. In designing the flexural reinforcement for the major moment of a particular beam for a particular station, the following steps are involved:

- Determine factored moments
- Determine required flexural reinforcement

1.7.1.1 Determine Factored Moments

In the design of flexural reinforcement of prestressed concrete beams, the factored moments for each load combination at a particular beam station are obtained by factoring the corresponding moments for different load cases, with the corresponding load factors.

The beam is then designed for the maximum positive and maximum negative factored moments obtained from all of the load combinations. Positive beam moments can be used to calculate bottom reinforcement. In such cases the beam may be designed as a rectangular or a flanged beam. Negative beam moments can be used to calculate top reinforcement. In such cases the beam may be designed as a rectangular or inverted flanged beam.

1.7.1.2 Determine Required Flexural Reinforcement

In the flexural reinforcement design process, both the tension and compression reinforcement shall be calculated. Compression reinforcement is added when the applied design moment exceeds the maximum moment capacity of a singly reinforced section. The user has the option of avoiding the compression reinforcement by increasing the effective depth, the width, or the strength of the concrete.

The design procedure is based on the simplified rectangular stress block, as shown in Figure 1-1 (ACI 10.2). Furthermore, it is assumed that the net tensile strain in the reinforcement shall not be less than 0.005 (tension controlled) (ACI 10.3.4). When the applied moment exceeds the moment capacity at this design condition, the area of compression reinforcement is calculated on the assumption that the additional moment will be carried by compression reinforcement and additional tension reinforcement.

The design procedure used, for both rectangular and flanged sections (L- and T-beams), is summarized in the subsections that follow. It is assumed that the design ultimate axial force does not exceed $\phi(0.1f_c' A_g)$ (ACI 10.3.5); hence all beams are designed for major direction flexure, shear, and torsion only.

1.7.1.2.1 Design of Rectangular Beams

The process first determines if the moment capacity provided by the post-tensioning tendons alone is enough. In calculating the capacity, it is assumed that $A_s = 0$. In that case, the moment capacity ϕM_n^0 is determined as follows:

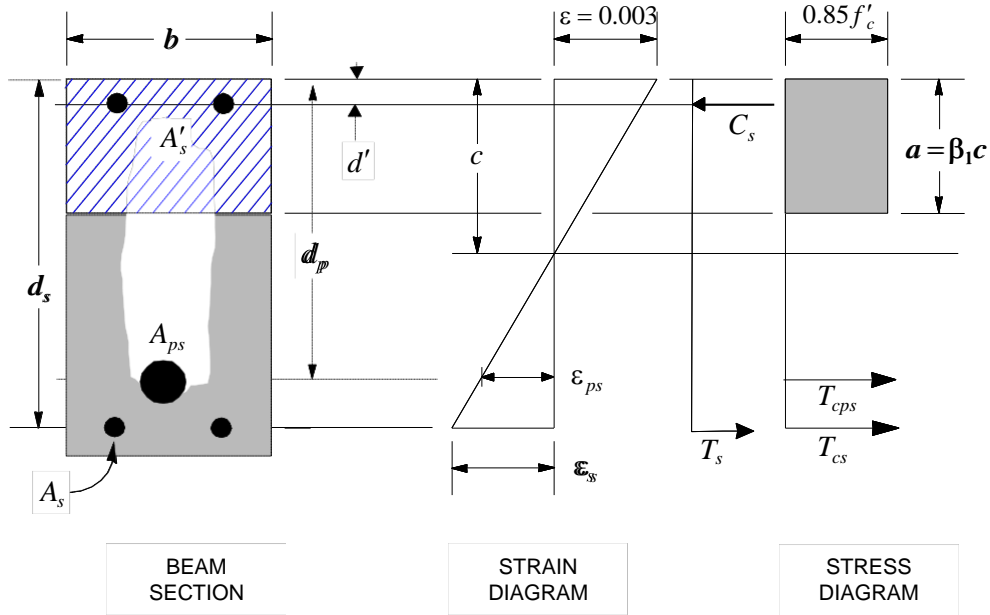

Figure 1-1 Rectangular Beam Design

The maximum depth of the compression zone, c_{max} , is calculated based on the limitation that the tension reinforcement strain shall not be less than ϵ_{smin} , which is equal to 0.005 for tension-controlled behavior (ACI 10.3.4):

$$c_{max} = \left(\frac{\epsilon_{cmax}}{\epsilon_{cmax} + \epsilon_{smin}} \right) d \quad \text{(ACI 10.2.2)}$$

where,

$$\epsilon_{cmax} = 0.003 \quad \text{(ACI 10.2.3)}$$

$$\epsilon_{smin} = 0.005 \quad \text{(ACI 10.3.4)}$$

Therefore, the limit $c \leq c_{max}$ is set for tension-controlled sections.

The maximum allowable depth of the rectangular compression block, a_{\max} , is given by:

$$a_{\max} = \beta_1 c_{\max} \quad (\text{ACI 10.2.7.1})$$

where β_1 is calculated as:

$$\beta_1 = 0.85 - 0.05 \left(\frac{f'_c - 4000}{1000} \right), \quad 0.65 \leq \beta_1 \leq 0.85 \quad (\text{ACI 10.2.7.3})$$

The process determines the depth of the neutral axis, c , by imposing force equilibrium, i.e., $C = T$. After the depth of the neutral axis has been determined, the stress in the post-tensioning steel, f_{ps} , is computed based on strain compatibility

for bonded tendons. For unbonded tendons, the code equations are used to compute the stress, f_{ps} in the post-tensioning steel.

Based on the calculated f_{ps} , the depth of the neutral axis is recalculated, and f_{ps} is further updated. After this iteration process has converged, the depth of the rectangular compression block is determined as follows:

$$a = \beta_1 c$$

- If $c \leq c_{\max}$ (ACI 10.3.4), the moment capacity of the section, provided by post-tensioning steel only, is computed as:

$$\phi M_n^0 = \phi A_{ps} f_{ps} \left(d_p - \frac{a}{2} \right)$$

- If $c > c_{\max}$ (ACI 10.3.4), a failure condition is declared.

If $M_u > \phi M_n^0$, calculates the moment capacity and the A_s required at the balanced condition. The balanced condition is taken as the marginal tension controlled case. In that case, it is assumed that the depth of the neutral axis, c is equal to c_{\max} . The stress in the post-tensioning steel, f_{ps} is then calculated and the area of required tension reinforcement, A_s is determined by imposing force equilibrium, i.e., $C = T$.

$$C = 0.85 f'_c a_{\max} b$$

Post-Tensioned Concrete Design

$$T = A_{ps} f_{ps}^{bal} + A_s^{bal} f_s^{bal}$$

$$A_s^{bal} = \frac{0.85 f_c' a_{max} b - A_{ps} f_{ps}^{bal}}{f_s^{bal}}$$

After the area of tension reinforcement has been determined, the capacity of the section with post-tensioning steel and tension reinforcement is computed as:

$$\phi M_n^{bal} = \phi A_{ps} f_{ps}^{bal} \left(d_p - \frac{a_{max}}{2} \right) + \phi A_s^{bal} f_s^{bal} \left(d_s - \frac{a_{max}}{2} \right)$$

In that case, it is assumed that the bonded tension reinforcement will yield, which is true for most cases. In the case that it does not yield, the stress in the reinforcement, f_s , is determined from the elastic-perfectly plastic stress-strain relationship. The f_y value of the reinforcement is then replaced with f_s in the preceding four equations. This case does not involve any iteration in determining the depth of the neutral axis, c .

1.7.1.2.1 Case 1: Post-tensioning steel is adequate

When $M_u < \phi M_n^0$, the amount of post-tensioning steel is adequate to resist the design moment M_u . Minimum reinforcement is provided to satisfy ductility requirements (ACI 18.9.3.2 and 18.9.3.3), i.e., $M_u < \phi M_n^0$.

1.7.1.2.2 Case 2: Post-tensioning steel plus tension reinforcement

In this case, the amount of post-tensioning steel, A_{ps} , alone is not sufficient to resist M_u , and therefore the required area of tension reinforcement is computed to supplement the post-tensioning steel. The combination of post-tensioning steel and tension reinforcement should result in $a < a_{max}$.

When $\phi M_n^0 < M_u < \phi M_n^{bal}$, determines the required area of tension reinforcement, A_s , iteratively to satisfy the design moment M_u and reports this required area of tension reinforcement. Since M_u is bounded by ϕM_n^0 at the lower end and ϕM_n^{bal} at the upper end, and ϕM_n^0 is associated with $A_s = 0$ and ϕM_n^{bal} is associated with $A_s = A_s^{bal}$, the required area will fall within the range of 0 to A_s^{bal} .

The tension reinforcement is to be placed at the bottom if M_u is positive, or at the top if M_u is negative.

1.7.1.2.1.3 Case 3: Post-tensioning steel and tension reinforcement are not adequate

When $M_u > \phi M_n^{bal}$, compression reinforcement is required (ACI 10.3.5). In this case ϵ_s assumes that the depth of the neutral axis, c , is equal to c_{max} . The values of f_{ps} and f_s reach their respective balanced condition values, f_{ps}^{max} and f_s^{bal} . The area of compression reinforcement, A'_s , is then determined as follows:

The moment required to be resisted by compression reinforcement and tension reinforcement is:

$$M_{us} = M_u - \phi M_n^{bal}$$

The required compression reinforcement is given by:

$$A'_s = \frac{M_{us}}{(f'_s - 0.85 f'_c)(d_e - d')\phi}, \text{ where}$$

$$f'_s = E_s \epsilon_{c \max} \left[\frac{c_{\max} - d'}{c_{\max}} \right] \leq f_y \quad (\text{ACI 10.2.2, 10.2.3, 10.2.4})$$

The tension reinforcement for balancing the compression reinforcement is given by:

$$A_s^{com} = \frac{M_{us}}{f_y (d_s - d')\phi}$$

Therefore, the total tension reinforcement, $A_s = A_s^{bal} + A_s^{com}$, and the total compression reinforcement is A'_s . A_s is to be placed at the bottom and A'_s is to be placed at the top if M_u is positive, and vice versa if M_u is negative.

1.7.1.2.2 Design of Flanged Beams

1.7.1.2.2.1 Flanged Beam Under Negative Moment

In designing for a factored negative moment, M_u (i.e., designing top reinforcement), the calculation of the reinforcement area is exactly the same as above, i.e., no flanged beam data is used.

1.7.1.2.2.2 Flanged Beam Under Positive Moment

The process first determines if the moment capacity provided by the post-tensioning tendons alone is enough. In calculating the capacity, it is assumed that $A_s = 0$. In that case, the moment capacity ϕM_n^0 is determined as follows:

The maximum depth of the compression zone, c_{\max} , is calculated based on the limitation that the tension reinforcement strain shall not be less than $\epsilon_{s\min}$, which is equal to 0.005 for tension-controlled behavior (ACI 10.3.4):

$$c_{\max} = \left(\frac{\epsilon_{c\max}}{\epsilon_{c\max} + \epsilon_{s\min}} \right) d \quad (\text{ACI 10.2.2})$$

where,

$$\epsilon_{c\max} = 0.003 \quad (\text{ACI 10.2.3})$$

$$\epsilon_{s\min} = 0.005 \quad (\text{ACI 10.3.4})$$

Therefore, the limit $c \leq c_{\max}$ is set for tension-controlled section:

The maximum allowable depth of the rectangular compression block, a_{\max} , is given by:

$$a_{\max} = \beta_1 c_{\max} \quad (\text{ACI 10.2.7.1})$$

where β_1 is calculated as:

$$\beta_1 = 0.85 - 0.05 \left(\frac{f'_c - 4000}{1000} \right), \quad 0.65 \leq \beta_1 \leq 0.85 \quad (\text{ACI 10.2.7.3})$$

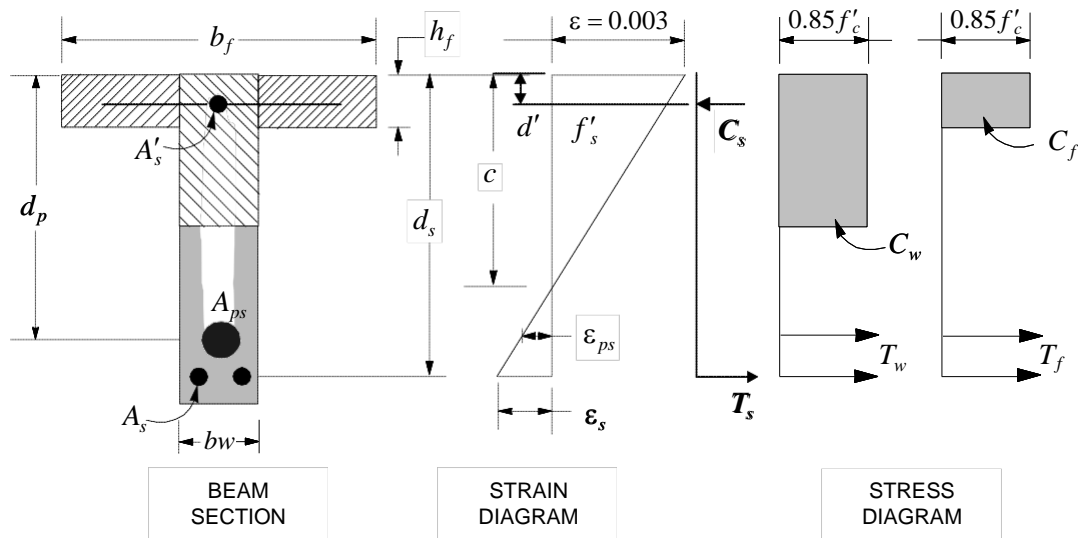

Figure 1-2 T-Beam Design

The process determines the depth of the neutral axis, c , by imposing force equilibrium, i.e., $C = T$. After the depth of the neutral axis has been determined, the stress in the post-tensioning steel, f_{ps} is computed based on strain compatibility for bonded tendons. For unbonded tendons, the code equations are used to compute the stress, f_{ps} in the post-tensioning steel. Based on the calculated f_{ps} , the depth of the neutral axis is recalculated, and f_{ps} is further updated. After this iteration process has converged, the depth of the rectangular compression block is determined as follows:

$$a = \beta_1 c$$

- If $c \leq c_{max}$ (ACI 10.3.4), the moment capacity of the section, provided by post-tensioning steel only, is computed as:

$$\phi M_n^0 = \phi A_{ps} f_{ps} \left(d_p - \frac{a}{2} \right)$$

- If $c > c_{max}$ (ACI 10.3.4), a failure condition is declared.

If $M_u > \phi M_n^0$, calculates the moment capacity and the A_s required at the balanced condition. The balanced condition is taken as the marginal tension-controlled case. In that case, it is assumed that the depth of the neutral

Post-Tensioned Concrete Design

axis c is equal to c_{\max} . The stress in the post-tensioning steel, f_{ps} , is then calculated and the area of required tension reinforcement, A_s , is determined by imposing force equilibrium, i.e., $C = T$.

- If $a \leq h_f$, the subsequent calculations for A_s are exactly the same as previously defined for the rectangular beam design. However, in that case the width of the beam is taken as b_f . Compression reinforcement is required if $a > a_{\max}$.
- If $a > h_f$, the calculation for A_s is given by:

$$C = 0.85 f'_c A_c^{comp}$$

where A_c^{com} is the area of concrete in compression, i.e.,

$$A_c^{com} = b_f h_f + b_w (a_{\max} - h_f)$$

$$T = A_{ps} f_{ps}^{bal} + A_s^{bal} f_s^{bal}$$

$$A_s^{bal} = \frac{0.85 f'_c A_c^{com} - A_{ps} f_{ps}^{bal}}{f_s^{bal}}$$

In that case, it is assumed that the bonded tension reinforcement will yield, which is true for most cases. In the case that it does not yield, the stress in the reinforcement, f_s , is determined from the elastic-perfectly plastic stress-strain relationship. The f_y value of the reinforcement is then replaced with f_s in the preceding four equations. This case does not involve any iteration in determining the depth of the neutral axis, c .

Case 1: Post-tensioning steel is adequate

When $M_u < \phi M_n^0$ the amount of post-tensioning steel is adequate to resist the design moment M_u . Minimum reinforcement is provided to satisfy ductility requirements (ACI 18.9.3.2 and 18.9.3.3), i.e., $M_u < \phi M_n^0$.

Case 2: Post-tensioning steel plus tension reinforcement

In this case, the amount of post-tensioning steel, A_{ps} , alone is not sufficient to resist M_u , and therefore the required area of tension reinforcement is computed

to supplement the post-tensioning steel. The combination of post-tensioning steel and tension reinforcement should result in $a < a_{\max}$

When $\phi M_n^0 < M_u < \phi M_n^{bal}$, determines the required area of tension reinforcement, A_s , iteratively to satisfy the design moment M_u and reports this required area of tension reinforcement. Since M_u is bounded by ϕM_n^0 at the lower end and ϕM_n^{bal} at the upper end, and ϕM_n^0 is associated with $A_s = 0$ and ϕM_n^{bal} is associated with $A_s = A_s^{bal}$, the required area will fall within the range of 0 to A_s .

The tension reinforcement is to be placed at the bottom if M_u is positive, or at the top if M_u is negative.

Case 3: Post-tensioning steel and tension reinforcement are not adequate

When $M_u > \phi M_n^{bal}$, compression reinforcement is required (ACI 10.3.5). In that case, assumes that the depth of the neutral axis, c , is equal to c_{\max} . The value of f_{ps} and f_s reach their respective balanced condition values, f_{ps}^{bal} and f_s^{bal} . The area of compression reinforcement, A_s' , is then determined as follows:

The moment required to be resisted by compression reinforcement and tension reinforcement is:

$$M_{us} = M_u - \phi M_n^{bal}$$

The required compression reinforcement is given by:

$$A_s' = \frac{M_{us}}{(f_s' - 0.85f_c')(d_s - d')\phi}, \text{ where}$$

$$f_s' = E_s \varepsilon_{c \max} \left[\frac{c_{\max} - d'}{c_{\max}} \right] \leq f_y \quad (\text{ACI 10.2.2, 10.2.3, and 10.2.4})$$

The tension reinforcement for balancing the compression reinforcement is given by:

Post-Tensioned Concrete Design

$$A_s^{com} = \frac{M_{us}}{f_y (d_s - d') \phi}$$

Therefore, the total tension reinforcement, $A_s = A_s^{bal} + A_s^{com}$, and the total compression reinforcement is A'_s . A_s is to be placed at the bottom and A'_s is to be placed at the top if M_u is positive, and vice versa if M_u is negative.

1.7.1.23 Ductility Requirements

also checks the following condition by considering the post-tensioning steel and tension reinforcement to avoid abrupt failure.

$$\phi M_n \geq 1.2 M_{cr} \quad (\text{ACI 18.8.2})$$

The preceding condition is permitted to be waived for the following:

- (a) Two-way, unbonded post-tensioned slabs
- (b) Flexural members with shear and flexural strength at least twice that required by ACI 9.2.

These exceptions currently are **NOT** handled .

1.7.1.24 Minimum and Maximum Reinforcement

The minimum flexural tension reinforcement required in a beam section is given by the following limit:

$$A_s \geq 0.004 A_{ct} \quad (\text{ACI 18.9.2})$$

where, A_{ct} is the area of the cross-section between the flexural tension face and the center of gravity of the gross section.

An upper limit of 0.04 times the gross web area on both the tension reinforcement and the compression reinforcement is imposed upon request as follows:

$$A_s \leq \begin{cases} 0.4bd & \text{Rectangular beam} \\ 0.4b_w d & \text{Flanged beam} \end{cases}$$

$$A'_s \leq \begin{cases} 0.04bd & \text{Rectangular beam} \\ 0.04b_w d & \text{Flanged beam} \end{cases}$$

1.7.2 Design Beam Shear Reinforcement

The shear reinforcement is designed for each load combination at each station along the length of the beam. In designing the shear reinforcement for a particular beam, for a particular loading combination, at a particular station due to the beam major shear, the following steps are involved:

- Determine the factored shear force, V_u .
- Determine the shear force, V_c that can be resisted by the concrete.
- Determine the shear reinforcement required to carry the balance.

The following three sections describe in detail the algorithms associated with these steps.

1.7.2.1 Determine Factored Shear Force

In the design of the beam shear reinforcement, the shear forces for each load combination at a particular beam station are obtained by factoring the corresponding shear forces for different load cases, with the corresponding load combination factors.

1.7.2.2 Determine Concrete Shear Capacity

The shear force carried by the concrete, V_c , is calculated as:

$$V_c = \min(V_{ci}, V_{cw}) \quad (\text{ACI 11.3.3})$$

where,

$$V_{ci} = 0.6\lambda\sqrt{f'_c}b_w d_p + V_d + \frac{V_i M_{cre}}{M_{\max}} \geq 1.7\lambda\sqrt{f'_c}b_w d \quad (\text{ACI 11.3.3.1})$$

Post-Tensioned Concrete Design

$$V_{cw} = (3.5\lambda\sqrt{f'_c} + 0.3f_{pc})b_w d_p + V_p \quad (\text{ACI 11.3.3.2})$$

$$d_p \geq 0.80h \quad (\text{ACI 11.3.3.1})$$

$$M_{cre} = \left(\frac{I}{y_t} \right) (6\lambda\sqrt{f'_c} + f_{pe} - f_d) \quad (\text{ACI 11.3.3.1})$$

where,

f_d = stress due to unfactored dead load, at the extreme fiber of the section where tensile stress is caused by externally applied loads, psi

f_{pe} = compress stress in concrete due to effective prestress forces only (after allowance for all prestress losses) at the extreme fiber of the section where tensile stress is caused by externally applied loads, psi

V_d = shear force at the section due to unfactored dead load, lbs

V_p = vertical component of effective prestress force at the section, lbs

V_{ci} = nominal shear strength provided by the concrete when diagonal cracking results from combined shear and moment

M_{cre} = moment causing flexural cracking at the section because of externally applied loads

M_{max} = maximum factored moment at section because of externally applied loads

V_i = factored shear force at the section because of externally applied loads occurring simultaneously with M_{max}

V_{cw} = nominal shear strength provided by the concrete when diagonal cracking results from high principal tensile stress in the web

For light-weight concrete, the $\sqrt{f'_c}$ term is multiplied by the shear strength reduction factor λ .

1.7.2.3 Determine Required Shear Reinforcement

The shear force is limited to a maximum of:

$$V_{\max} = V_c + (8\lambda\sqrt{f'_c})b_w d \quad (\text{ACI 11.4.7.9})$$

Given V_u , V_c , and V_{\max} , the required shear reinforcement is calculated as follows where, ϕ , the strength reduction factor, is 0.75 (ACI 9.3.2.3).

- If $V_u \leq 0.5\phi V_c$

$$\frac{A_v}{s} = 0 \quad (\text{ACI 11.4.6.1})$$

- If $0.5\phi V_c < V_u \leq \phi V_{\max}$

$$\frac{A_v}{s} = \frac{(V_u - \phi V_c)}{\phi f_{yt} d} \quad (\text{ACI 11.4.7.1, 11.4.7.2})$$

$$\frac{A_v}{s} \geq \max\left\{\frac{0.75\lambda\sqrt{f'_c}}{f_{yt}}b_w, \frac{50b_w}{f_{yt}}\right\} \quad (\text{ACI 11.4.6.3})$$

- If $V_u > \phi V_{\max}$, a failure condition is declared (ACI 11.4.7.9).

For members with an effective prestress force not less than 40 percent of the tensile strength of the flexural reinforcement, the required shear reinforcement is computed as follows (ACI 11.5.6.3, 11.5.6.4):

$$\frac{A_v}{s} \geq \min\left\{\max\left\{\frac{0.75\lambda\sqrt{f'_c}}{f_y}b_w, \frac{50b_w}{f_y}\right\}, \frac{A_{ps}f_{pu}}{80f_{yt}d}\sqrt{\frac{d}{b_w}}\right\}$$

- If V_u exceeds the maximum permitted value of ϕV_{\max} , the concrete section should be increased in size (ACI 11.5.7.9).

Note that if torsion design is considered and torsion reinforcement is needed, the equation given in ACI 11.5.6.3 does not need to be satisfied independently. See the next section *Design of Beam Torsion Reinforcement* for details.

If the beam depth h is less than the minimum of 10 in, $2.5h$, and $0.5b_w$, the minimum shear reinforcement given by ACI 11.5.6.3 is not enforced (ACI 11.5.6.1(c)).

The maximum of all of the calculated A_v/s values, obtained from each load combination, is reported along with the controlling shear force and associated load combination.

The beam shear reinforcement requirements considered are based purely on shear strength considerations. Any minimum stirrup requirements to satisfy spacing and volumetric considerations must be investigated independently by the user.

1.7.3 Design Beam Torsion Reinforcement

The torsion reinforcement is designed for each design load combination at each station along the length of the beam. The following steps are involved in designing the shear reinforcement for a particular station due to the beam torsion:

- Determine the factored torsion, T_u .
- Determine special section properties.
- Determine critical torsion capacity.
- Determine the torsion reinforcement required.

1.7.3.1 Determine Factored Torsion

In the design of beam torsion reinforcement, the torsions for each load combination at a particular beam station are obtained by factoring the corresponding torsions for different load cases with the corresponding load combination factors (ACI 11.6.2).

In a statically indeterminate structure where redistribution of the torsion in a member can occur due to redistribution of internal forces upon cracking, the

design T_u is permitted to be reduced in accordance with the code (ACI 11.6.2.2). However it is not done automatically to redistribute the internal forces and reduce T_u .

1.7.3.2 Determine Special Section Properties

For torsion design, special section properties, such as A_{cp} , A_{oh} , A_o , p_{cp} , and p_h are calculated. These properties are described in the following (ACI 2.1).

- A_{cp} = Area enclosed by outside perimeter of concrete cross-section
- A_{oh} = Area enclosed by centerline of the outermost closed transverse torsional reinforcement
- A_o = Gross area enclosed by shear flow path
- p_{cp} = Outside perimeter of concrete cross-section
- p_h = Perimeter of centerline of outermost closed transverse torsional reinforcement

In calculating the section properties involving reinforcement, such as A_{oh} , A_o , and p_h , it is assumed that the distance between the centerline of the outermost closed stirrup and the outermost concrete surface is 1.75 inches. This is equivalent to 1.5 inches clear cover and a #4 stirrup. For torsion design of flanged beam sections, it is assumed that placing torsion reinforcement in the flange

area is inefficient. With this assumption, the flange is ignored for torsion reinforcement calculation. However, the flange is considered during T_{cr} calculation. With this assumption, the special properties for a rectangular beam section are given as:

$$A_{cp} = bh \quad (\text{ACI 11.6.1, 2.1})$$

$$A_{oh} = (b - 2c)(h - 2c) \quad (\text{ACI 11.6.3.1, 2.1, R11.6.3.6(b)})$$

$$A_o = 0.85 A_{oh} \quad (\text{ACI 11.6.3.6, 2.1})$$

$$p_{cp} = 2b + 2h \quad (\text{ACI 11.6.1, 2.1})$$

Post-Tensioned Concrete Design

$$p_h = 2(b - 2c) + 2(h - 2c) \quad (\text{ACI 11.6.3.1, 2.1})$$

where, the section dimensions b , h , and c are shown in Figure 1-3. Similarly, the special section properties for a flanged beam section are given as:

$$A_{cp} = b_w h + (b_f - b_w) h_f \quad (\text{ACI 11.6.1, 2.1})$$

$$A_{oh} = (b_w - 2c)(h - 2c) \quad (\text{ACI 11.6.3.1, 2.1, R11.6.3.6(b)})$$

$$A_o = 0.85 A_{oh} \quad (\text{ACI 11.6.3.6, 2.1})$$

$$p_{cp} = 2b_f + 2h \quad (\text{ACI 11.6.1, 2.1})$$

$$p_h = 2(h - 2c) + 2(b_w - 2c) \quad (\text{ACI 11.6.3.1, 2.1})$$

where the section dimensions b_f , b_w , h , h_f , and c for a flanged beam are shown in Figure 1-3. Note that the flange width on either side of the beam web is limited to the smaller of $4h_f$ or $(h - h_f)$ (ACI 13.2.4).

1.7.3.3 Determine Critical Torsion Capacity

The critical torsion capacity, T_{cr} , for which the torsion in the section can be ignored is calculated as:

$$T_{cr} = \phi \lambda \sqrt{f'_c} \left[\frac{A_{cp}^2}{p_{cp}} \right] \sqrt{1 + \frac{f_{pc}}{4 \sqrt{f'_c}}} \quad (\text{ACI 11.6.1(b)})$$

where A_{cp} and p_{cp} are the area and perimeter of the concrete cross-section as described in detail in the previous section; f_{pc} is the concrete compressive stress at the centroid of the section; ϕ is the strength reduction factor for torsion, which is equal to 0.75 by default (ACI 9.3.2.3); and f'_c is the specified concrete compressive strength.

1.7.3.4 Determine Torsion Reinforcement

If the factored torsion T_u is less than the threshold limit, T_{cr} , torsion can be ignored (ACI 11.6.1). In that case, no torsion reinforcement is required. However, if T_u exceeds the threshold limit, T_{cr} , it is assumed that the torsional resistance is provided by closed stirrups, longitudinal bars, and compression diagonal (ACI R11.6.3.6).

If $T_u > T_{cr}$ the required closed stirrup area per unit spacing, A_t/s , is calculated as:

$$\frac{A_t}{s} = \frac{T_u \tan \theta}{\phi 2A_o f_{yt}} \quad (\text{ACI 11.6.3.6})$$

and the required longitudinal reinforcement is calculated as:

$$A_l = \frac{T_u p_h}{\phi 2A_o f_y \tan \theta} \quad (\text{ACI 11.6.3.7, 11.6.3.6})$$

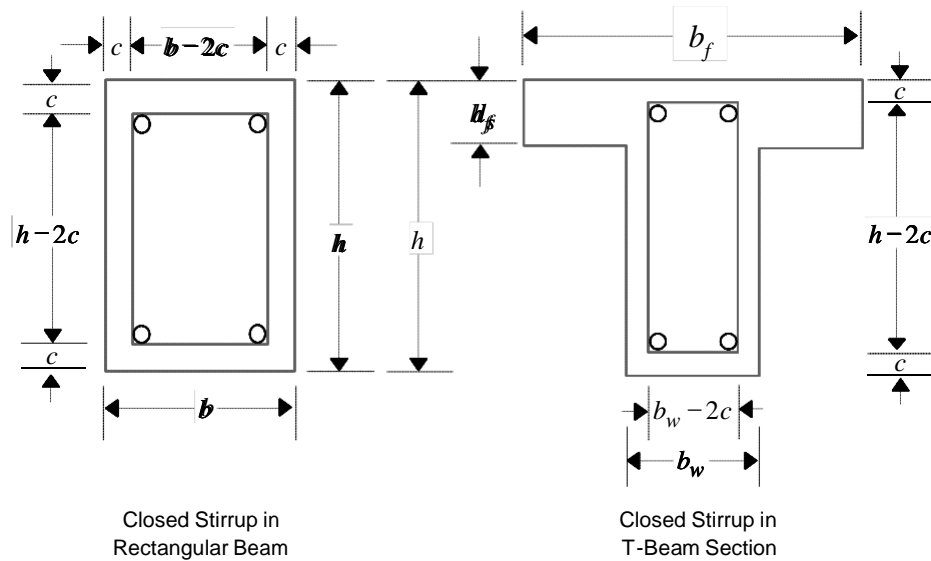

Figure 1-3 Closed stirrup and section dimensions for torsion design

where, the minimum value of A_t/s is taken as:

$$\frac{A_t}{s} = \frac{25}{f_{yt}} b_w \quad (\text{ACI 11.6.5.3})$$

and the minimum value of A_l is taken as follows:

Post-Tensioned Concrete Design

$$A_t = \frac{5\lambda\sqrt{f'_c}A_{cp}}{f_y} - \left(\frac{A_t}{s}\right) P \left(\frac{f_{yt}}{f_y}\right) \quad (\text{ACI 11.6.5.3})$$

In the preceding expressions, θ is taken as 45 degrees for prestressed members with an effective prestress force less than 40 percent of the tensile strength of the longitudinal reinforcement; otherwise θ is taken as 37.5 degrees.

An upper limit of the combination of V_u and T_u that can be carried by the section is also checked using the equation:

$$\sqrt{\left(\frac{V_u}{b_w d}\right)^2 + \left(\frac{T_u P_h}{1.7 A_{oh}^2}\right)^2} \leq \phi \left(\frac{V_c}{b_w d} + 8\sqrt{f'_c} \right) \quad (\text{ACI 11.6.3.1})$$

For rectangular sections, b_w is replaced with b . If the combination of V_u and T_u exceeds this limit, a failure message is declared. In that case, the concrete section should be increased in size.

When torsional reinforcement is required ($T_u > T_{cr}$), the area of transverse closed stirrups and the area of regular shear stirrups must satisfy the following limit.

$$\left(\frac{A_v}{s} + 2\frac{A_t}{s}\right) \geq \max\left\{0.75\lambda\frac{\sqrt{f'_c}}{f_{yt}}b_w, \frac{50b_w}{f_y}\right\} \quad (\text{ACI 11.6.5.2})$$

If this equation is not satisfied with the originally calculated A_v/s and A_t/s , A_v/s is increased to satisfy this condition. In that case, A_v/s does not need to satisfy the ACI Section 11.5.6.3 independently.

The maximum of all of the calculated A_t and A_t/s values obtained from each load combination is reported along with the controlling combination.

The beam torsion reinforcement requirements considered are based purely on strength considerations. Any minimum stirrup requirements and longitudinal reinforcement requirements to satisfy spacing considerations must be investigated independently by the user.

1.8 Slab Design

Similar to conventional design, the slab design procedure involves defining sets of strips in two mutually perpendicular directions. The locations of the strips are usually governed by the locations of the slab supports. The moments for a particular strip are recovered from the analysis and a flexural design is completed using the ultimate strength design method (ACI 318-08) for prestressed reinforced concrete as described in the following sections. To learn more about the design strips, refer to the section entitled " Design Features" in the *Key Features and Terminology* manual.

1.8.1 Design for Flexure

The process designs the slab on a strip-by-strip basis. The moments used for the design of the slab elements are the nodal reactive moments, which are obtained by multiplying the slab element stiffness matrices by the element nodal displacement vectors. Those moments will always be in static equilibrium with the applied loads, irrespective of the refinement of the finite element mesh.

The design of the slab reinforcement for a particular strip is completed at specific locations along the length of the strip. Those locations correspond to the element boundaries. Controlling reinforcement is computed on either side of those element boundaries. The slab flexural design procedure for each load combination involves the following:

- Determine factored moments for each slab strip.
- Determine the capacity of post-tensioned sections.
- Design flexural reinforcement for the strip.

These three steps are described in the subsection that follow and are repeated for every load combination. The maximum reinforcement calculated for the top and bottom of the slab within each design strip, along with the corresponding controlling load combination, is obtained and reported.

1.8.1.1 Determine Factored Moments for the Strip

For each element within the design strip, for each load combination, the process calculates the nodal reactive moments. The nodal moments are then added to get the strip moments.

1.8.1.2 Determine Capacity of Post-Tensioned Sections

Calculation of the post-tensioned section capacity is identical to that described earlier for rectangular beam sections.

1.8.1.3 Design Flexural Reinforcement for the Strip

The reinforcement computation for each slab design strip, given the bending moment, is identical to the design of rectangular beam sections described earlier (or to the flanged beam if the slab is ribbed). In some cases, at a given design section in a design strip, there may be two or more slab properties across the width of the design strip. In that case, the design the tributary width associated with each of the slab properties separately using its tributary bending moment. The reinforcement obtained for each of the tributary widths is summed to obtain the total reinforcement for the full width of the design strip at the considered design section. This method is used when drop panels are included. Where openings occur, the slab width is adjusted accordingly.

1.8.1.3.1 Minimum and Maximum Slab Reinforcement

The minimum flexural tension reinforcement required for each direction of a slab is given by the following limits (ACI 7.12.2):

$$A_{s,\min} = 0.0020 bh \text{ for } f_y = 40 \text{ ksi or } 50 \text{ ksi} \quad (\text{ACI 7.12.2.1(a)})$$

$$A_{s,\min} = 0.0018 bh \text{ for } f_y = 60 \text{ ksi} \quad (\text{ACI 7.12.2.1(b)})$$

$$A_{s,\min} = \frac{0.0018 \times 60000}{f_y} bh \text{ for } f_y > 60 \text{ ksi} \quad (\text{ACI 7.12.2.1(c)})$$

Reinforcement is not required in positive moment areas where f_t , the extreme fiber stress in tension in the precompressed tensile zone at service loads (after all prestress losses occurs) does not exceed $2\sqrt{f'_c}$ (ACI 18.9.3.1).

In positive moment areas where the computed tensile stress in the concrete at service loads exceeds $2\sqrt{f'_c}$, the minimum area of bonded reinforcement is computed as:

$$A_{s,\min} = \frac{N_c}{0.5f_y}, \text{ where } f_y \leq 60 \text{ ksi} \quad (\text{ACI 18.9.3.2})$$

In negative moment areas at column supports, the minimum area of bonded reinforcement in the top of slab in each direction is computed as:

$$A_{s,\min} = 0.0075A_{cf} \quad (\text{ACI 18.3.9.3})$$

where A_{cf} is the larger gross cross-sectional area of the slab-beam strip in the two orthogonal equivalent frames intersecting a column in a two-way slab system.

When spacing of tendons exceed 54 inches, additional bonded shrinkage and temperature reinforcement (as computed above, ACI 7.12.2.1) is required between the tendons at slab edges, extending from the slab edge for a distance equal to the tendon spacing (ACI 7.12.3.3)

In addition, an upper limit on both the tension reinforcement and compression reinforcement has been imposed to be 0.04 times the gross cross-sectional area. Note that the requirements when $f_y > 60$ ksi currently are not handled.

1.8.2 Check for Punching Shear

The algorithm for checking punching shear is detailed in the section entitled “Slab Punching Shear Check” in the *Key Features and Terminology* manual. Only the code specific items are described in the following sections.

1.8.2.1 Critical Section for Punching Shear

The punching shear is checked on a critical section at a distance of $d/2$ from the face of the support (ACI 11.11.1.2). For rectangular columns and concentrated loads, the critical area is taken as a rectangular area with the sides parallel to the sides of the columns or the point loads (ACI 11.11.1.3). Figure 1-4 shows the auto punching perimeters considered for the various column shapes. The column location (i.e., interior, edge, corner) and the punching perimeter may be overwritten using the Punching Check Overwrites.

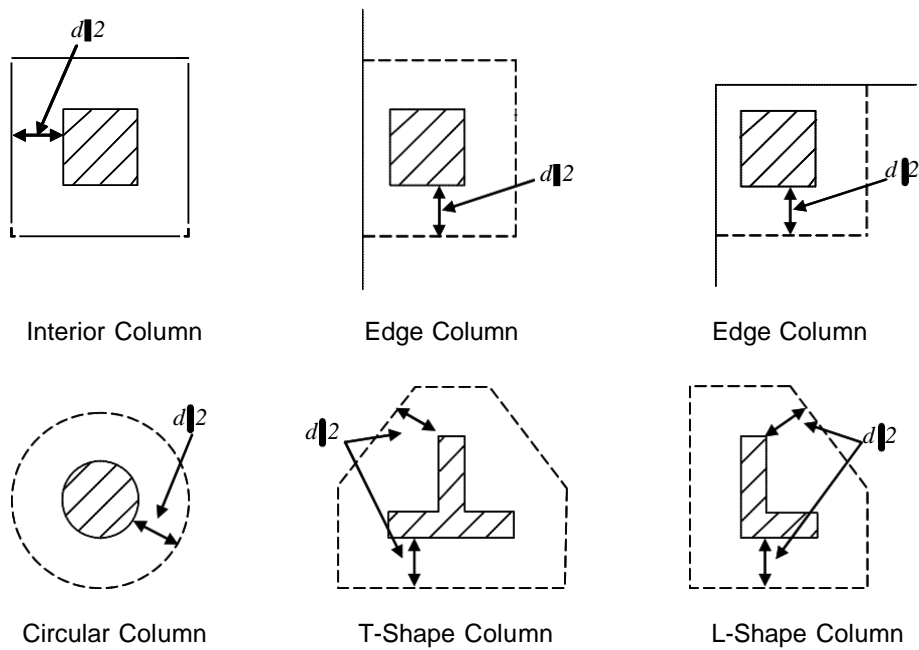

Figure 1-4 Punching Shear Perimeters

1.8.2.2 Transfer of Unbalanced Moment

The fraction of unbalanced moment transferred by flexure is taken to be $\gamma_f M_u$ and the fraction of unbalanced moment transferred by eccentricity of shear is taken to be $\gamma_v M_u$.

$$\gamma_f = \frac{1}{1 + (2/3)\sqrt{b_1/b_2}} \quad (\text{ACI 13.5.3.2})$$

$$\gamma_v = 1 - \gamma_f \quad (\text{ACI 13.5.3.1})$$

For flat plates, γ_v is determined from the following equations taken from ACI 421.2R-07 [ACI 2007] *Seismic Design of Punching Shear Reinforcement in Flat Plates*.

For interior columns,

$$\gamma_{vx} = 1 - \frac{1}{1 + (2/3)\sqrt{l_y/l_x}} \quad (\text{ACI 421.2 C-11})$$

$$\gamma_{vy} = 1 - \frac{1}{1 + (2/3)\sqrt{l_x/l_y}} \quad (\text{ACI 421.2 C-12})$$

For edge columns,

$$\gamma_{vx} = \text{same as for interior columns} \quad (\text{ACI 421.2 C-13})$$

$$\gamma_{vy} = 1 - \frac{1}{1 + (2/3)\sqrt{l_x/l_y} - 0.2} \quad (\text{ACI 421.2 C-14})$$

$$\gamma_{vy} = 0 \text{ when } l_x/l_y \leq 0.2$$

For corner columns,

$$\gamma_{vx} = 0.4 \quad (\text{ACI 421.2 C-15})$$

$$\gamma_{vy} = \text{same as for edge columns} \quad (\text{ACI 421.2 C-16})$$

where b_1 is the width of the critical section measured in the direction of the span and b_2 is the width of the critical section measured in the direction perpendicular to the span. The values l_x and l_y are the projections of the shear-critical section onto its principal axes, x and y , respectively.

1.8.2.3 Determine Concrete Capacity

The concrete punching shear stress capacity of a two-way prestressed section is taken as:

Post-Tensioned Concrete Design

$$v_c = \phi \left(\beta_p \sqrt{f'_c} + 0.3 f_{pc} \right) + v_p \quad (\text{ACI 11.11.2.2})$$

$$\beta_p = \min \left(3.5, \left(\frac{\alpha_s d}{b_o} + 1.5 \right) \right) \quad (\text{ACI 11.11.2.2})$$

where, β_p is the factor used to compute v_c in prestressed slab; b_o is the perimeter of the critical section; f_{pc} is the average value of f_{pc} in the two directions; v_p is the vertical component of all effective prestress stresses crossing the critical section; and α_s is a scale factor based on the location of the critical section.

$$\alpha_s = \begin{cases} 40 & \text{for interior columns,} \\ 30 & \text{for edge columns, and} \\ 20 & \text{for corner columns.} \end{cases} \quad (\text{ACI 11.11.2.1})$$

The concrete capacity v_c computed from ACI 11.12.2.2 is permitted only when the following conditions are satisfied:

- The column is farther than four times the slab thickness away from any discontinuous slab edges.
- The value of $\sqrt{f'_c}$ is taken no greater than 70 psi.
- In each direction, the value of f_{pc} is within the range:

$$125 \leq f_{pc} \leq 500 \text{ psi}$$

In thin slabs, the slope of the tendon profile is hard to control and special care should be exercised in computing v_p . In case of uncertainty between the design and as-built profile, a reduced or zero value for v_p should be used.

If the preceding three conditions are not satisfied, the concrete punching shear stress capacity of a two-way prestressed section is taken as the minimum of the following three limits:

$$v_c = \min \left\{ \begin{array}{l} \phi \left(2 + \frac{4}{\beta_c} \right) \lambda \sqrt{f'_c} \\ \phi \left(2 + \frac{\alpha_s d}{b_c} \right) \lambda \sqrt{f'_c} \\ \phi 4 \lambda \sqrt{f'_c} \end{array} \right. \quad (\text{ACI 11.11.2.1})$$

where, β_c is the ratio of the maximum to the minimum dimensions of the critical section, b_o is the perimeter of the critical section, and α_s is a scale factor based on the location of the critical section (ACI 11.12.2.1).

A limit is imposed on the value of $\sqrt{f'_c}$ as:

$$\sqrt{f'_c} \leq 100 \quad (\text{ACI 11.1.2})$$

1.8.2.4 Determine Capacity Ratio

Given the punching shear force and the fractions of moments transferred by eccentricity of shear about the two axes, the shear stress is computed assuming linear variation along the perimeter of the critical section. The ratio of the maximum shear stress and the concrete punching shear stress capacity is reported as the punching shear capacity ratio .

1.8.3 Design Punching Shear Reinforcement

The use of shear studs as shear reinforcement in slabs is permitted, provided that the effective depth of the slab is greater than or equal to 6 inches, and not less than 16 times the shear reinforcement bar diameter (ACI 11.11.3). If the slab thickness does not meet these requirements, the punching shear reinforcement is not designed and the slab thickness should be increased by the user.

The algorithm for designing the required punching shear reinforcement is used when the punching shear capacity ratio exceeds unity. The *Critical Section for Punching Shear and Transfer of Unbalanced Moment* as described in the ear-

lier sections remain unchanged. The design of punching shear reinforcement is carried out as described in the subsections that follow.

1.8.3.1 Determine Concrete Shear Capacity

The concrete punching shear stress capacity of a two-way prestressed section with punching shear reinforcement is as previously determined, but limited to:

$$v_c \leq \phi 2\lambda_v \sqrt{f'_c} \text{ for shear links} \quad (\text{ACI 11.11.3.1})$$

$$v_c \leq \phi 3\lambda_v \sqrt{f'_c} \text{ for shear studs} \quad (\text{ACI 11.11.5.1})$$

1.8.3.2 Determine Required Shear Reinforcement

The shear force is limited to a maximum of:

$$V_{\max} = 6 \sqrt{f'_c} b_o d \text{ for shear links} \quad (\text{ACI 11.11.3.2})$$

$$V_{\max} = 8 \sqrt{f'_c} b_o d \text{ for shear studs} \quad (\text{ACI 11.11.5.1})$$

Given V_u , V_c , and V_{\max} , the required shear reinforcement is calculated as follows, where, ϕ , the strength reduction factor, is 0.75 (ACI 9.3.2.3).

$$\frac{A_v}{s} = \frac{(V_u - \phi V_c)}{\phi f_{ys} d} \quad (\text{ACI 11.4.7.1, 11.4.7.2})$$

$$\frac{A_v}{s} \geq 2 \frac{\sqrt{f'_c}}{f_y} b_o \text{ for shear studs}$$

- If $V_u > \phi V_{\max}$, a failure condition is declared. (ACI 11.11.3.2)
- If V_u exceeds the maximum permitted value of ϕV_{\max} , the concrete section should be increased in size.

1.8.3.3 Determine Reinforcement Arrangement

Punching shear reinforcement in the vicinity of rectangular columns should be arranged on peripheral lines, i.e., lines running parallel to and at constant dis-

tances from the sides of the column. Figure 1-5 shows a typical arrangement of shear reinforcement in the vicinity of a rectangular interior, edge, and corner column.

The distance between the column face and the first line of shear reinforcement shall not exceed $d/2$ (ACI R11.3.3, 11.11.5.2). The spacing between adjacent shear reinforcement in the first line of shear reinforcement shall not exceed $2d$ measured in a direction parallel to the column face (ACI 11.11.3.3).

Punching shear reinforcement is most effective near column corners where there are concentrations of shear stress. Therefore, the minimum number of lines of shear reinforcement is 4, 6, and 8, for corner, edge, and interior columns respectively.

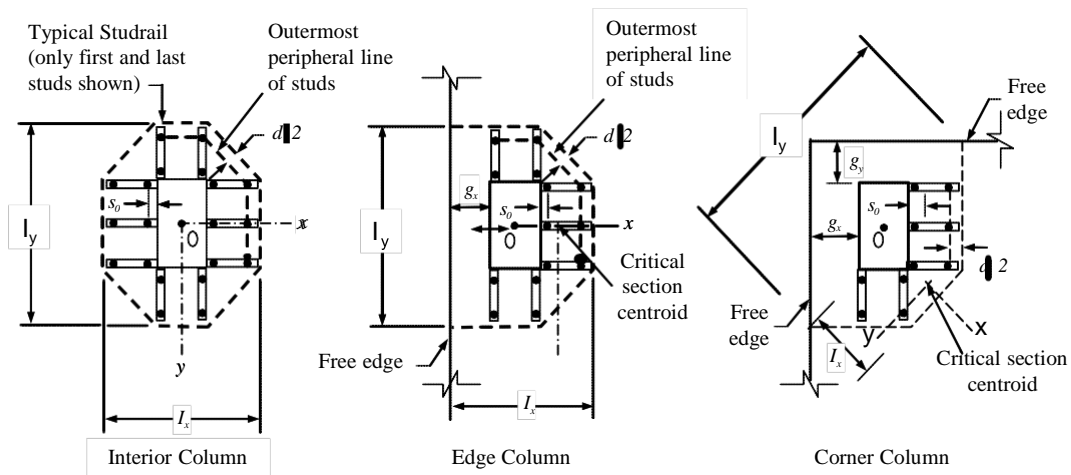

Figure 1-5 Typical arrangement of shear studs and critical sections outside shear-reinforced zone

1.8.3.4 Determine Reinforcement Diameter, Height, and Spacing

The punching shear reinforcement is most effective when the anchorage is close to the top and bottom surfaces of the slab. The cover of anchors should not be less than the minimum cover specified in ACI 7.7 plus half of the diameter of the flexural reinforcement.

Punching shear reinforcement in the form of shear studs is generally available in 3/8-, 1/2-, 5/8-, and 3/4-inch diameters.

Post-Tensioned Concrete Design

When specifying shear studs, the distance, s_o , between the column face and the first peripheral line of shear studs should not be smaller than $0.35d$. The limits of s_o and the spacing, s , between the peripheral lines are specified as:

$$s_o \leq 0.5d \quad (\text{ACI 11.11.5.2})$$

$$s \leq \begin{cases} 0.75d & v_u \leq 6\phi\lambda\sqrt{f'_c} \\ 0.50d & v_u > 6\phi\lambda\sqrt{f'_c} \end{cases} \quad (\text{ACI 11.11.5.2})$$

$$g \leq 2d \quad (\text{ACI 11.11.5.3})$$

f
o
r

Post-Tensioned Concrete Design

The limits of s and the spacing, s , between the links are specified as:

$$s_o \leq 0.5d \quad (\text{ACI 11.11.3})$$

$$s \leq 0.50d \quad (\text{ACI 11.11.3})$$